

AIRCRAFT SPECIALTY



FLIGHTLINES

Thank you for your RV-10 Firewall Forward Hose purchase.

You are already receiving our PREMIUM INTEGRAL FIRESLEEVE hose assemblies as standard with your VANS RV10 FWF hose kit. However, we recognize that many builders will want to deviate slightly from the plans or make small adjustments to their setup. We have compiled a list of the most common changes that builders make as well as a list of hoses to delete from VANS when making these changes.

All hoses that you received with your kit are designed to be installed as per the VANS install manual with the following exceptions if you make changes.

CHOICE #1 – Manifold Pressure Transducer

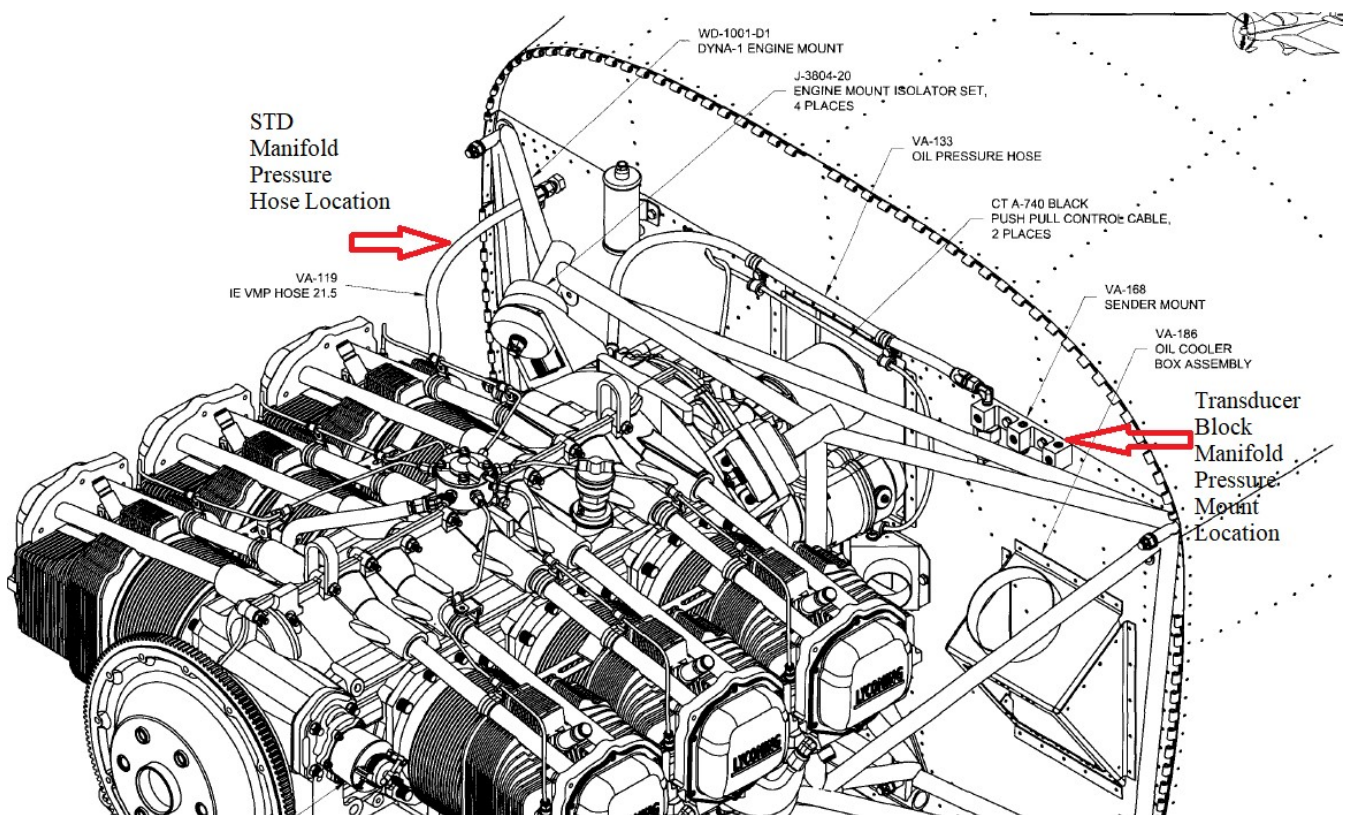

If you look at the picture on the preceding page, the Std length hose is shown by a red arrow in the upper left of the picture. With that hose, the transducer can either be mounted firewall aft, or that hose can be routed to mount the transducer to the engine mount and secure it with an adel clamp.

If you choose the “Transducer Block” mount location, we will build you a longer manifold pressure hose that will allow you to route the hose so that it will allow attachment of the transducer at the firewall mounted block. This hose comes in two different configurations. You can choose either a STANDARD option, which is a hose with a standard anti-abrasion coating. Alternatively, you can choose the INTEGRAL FIRESLEEVE version, which is built the same as all the rest of your firewall forward hose assemblies with an Integral Firesleeve Coating. The option for mounting the transducer on the block is only applicable for GARMIN transducer installations.

In addition to the hose, this kit ALSO includes a 45 degree steel restrictor fitting to screw into the manifold pressure port of the engine to help dampen out the pulses to make the manifold pressure read more accurately. It also includes an elbow fitting for the transducer manifold block to screw the hose into.

DELETION LIST FOR CHOICE #1: VA-119

CHOICE #2 – FUEL FLOW TRANSDUCER FIREWALL FORWARD

If you purchased our Firewall aft fuel hose package, you had a choice to mount the fuel flow transducer either in the tunnel, or to mount it firewall forward. As per the VANS plans, the transducer is mounted in the center tunnel. There are a variety of benefits to moving the transducer forward of the firewall. First off, readings are more accurate when the transducer is on the Pressure side of both pumps, rather than being downstream of the electric pump, and upstream of the mechanical pump. The manufacturer of the FT-60 Red Cube recommends that the transducer be placed AFTER the mechanical fuel pump.

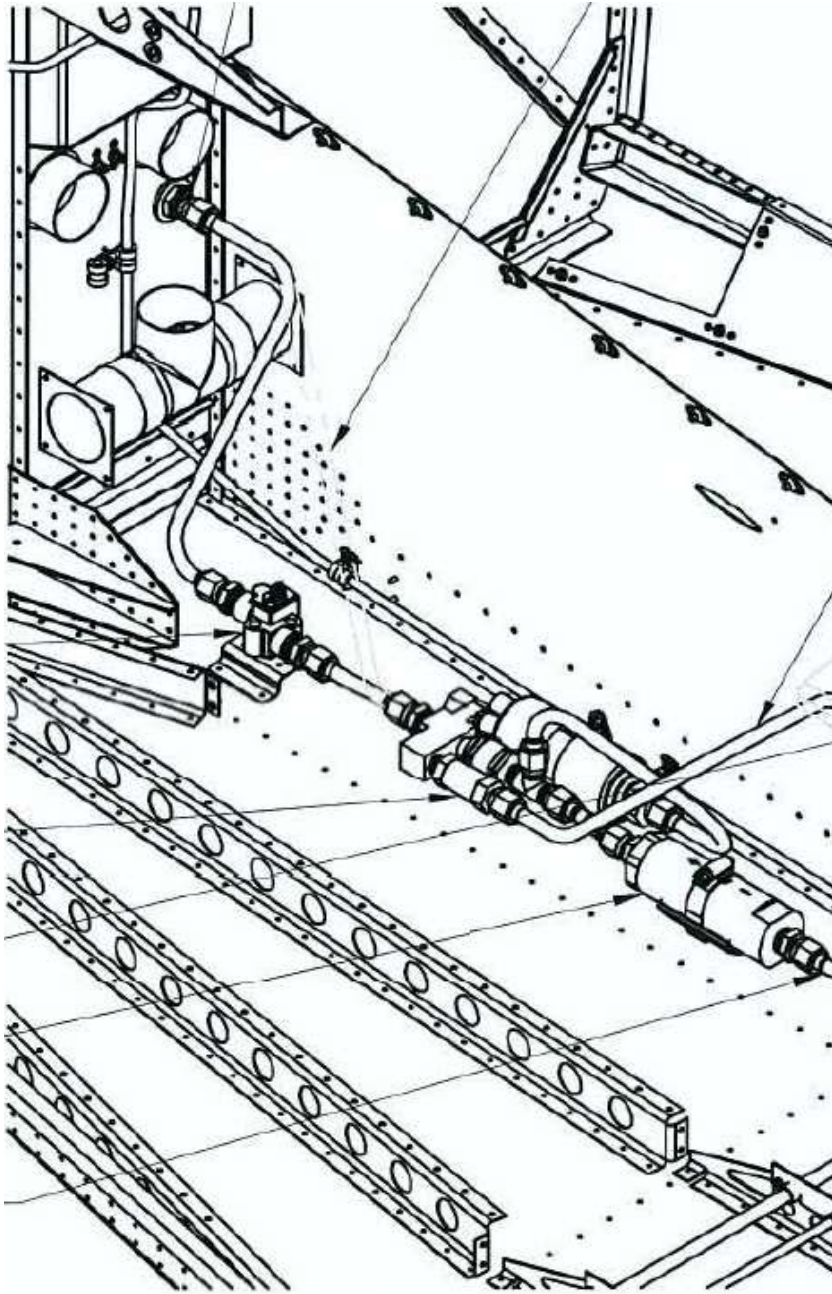

Pictured to the left is the STOCK VANS setup with the fuel flow transducer in the tunnel. If you have your aircraft configured this way, no change is necessary to the stock FWF hose package.

If you have our kit or you have set up your aircraft to eliminate the transducer in the tunnel, then you will be mounting your transducer firewall forward, and you will want to ensure you order this kit which allows relocation of the Red Cube firewall Forward.

The pictures on the FOLLOWING PAGE show the relocated RED CUBE mounting location. Please note that we provide the hoses, but no adel clamps or mounting hardware for securing.

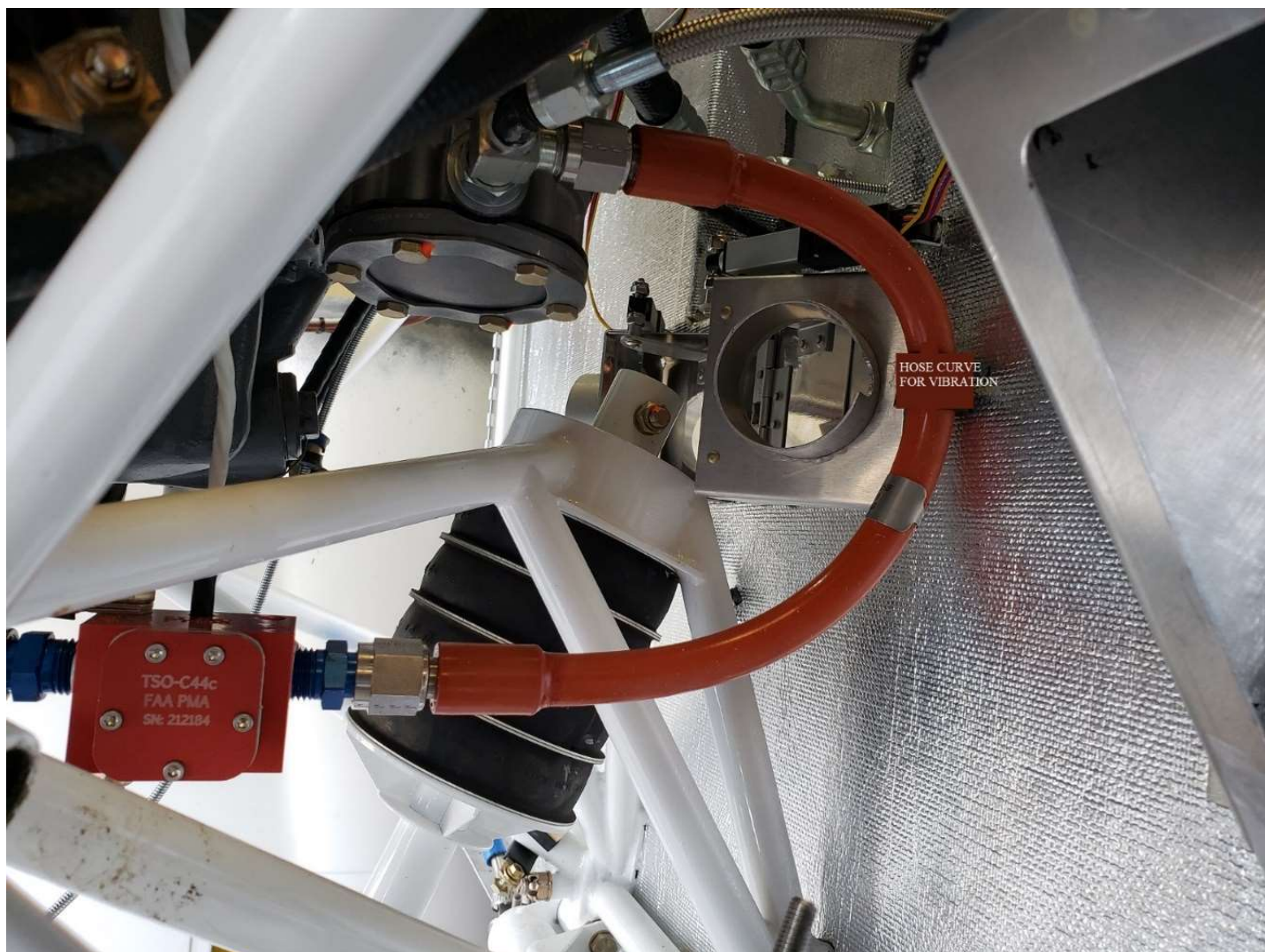

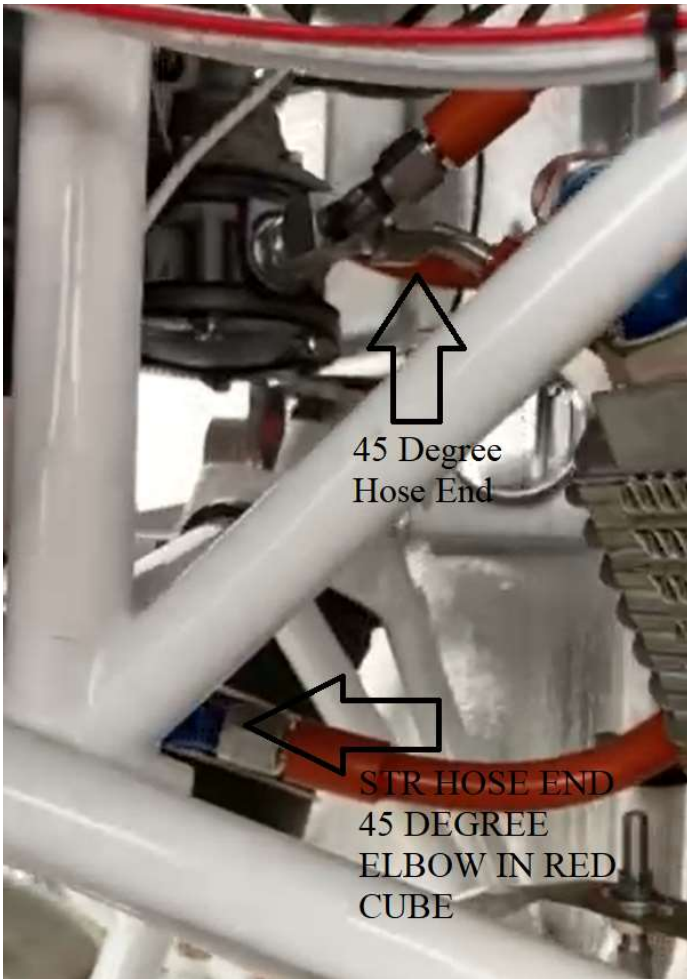



IF YOU HAVE AN EXISTING RV10 AND WOULD LIKE TO RELOCATE YOUR TRANSDUCER FROM THE TUNNEL TO THE FIREWALL, YOU CAN ORDER OUR **“FUEL FLOW TRANSDUCER FIREWALL FORWARD KIT PLUS FIREWALL AFT HOSE”** THIS WILL PROVIDE YOU WITH TWO HOSES FIREWALL FORWARD FOR YOUR TRANSDUCER, AND ONE HOSE IN YOUR TUNNEL WHICH WILL GO FROM THE FUEL PUMP TO THE FIREWALL.

DELETIONS: Delete the VA-189 Hose from your VANS order if you plan to mount your transducer Firewall Forward.

CHOICE #3 PMAG SETUP

1. If you are choosing to utilize PMAG style electronic ignition on your RV10 we have you covered. Our PMAG install kit for the RV10 can be utilized for either single or dual pmags. We include the components for both setups. If you are currently utilizing a single PMAG, save the extra fitting for later, and no changes will be necessary to your hoses if you decide to upgrade to a second one down the road.

There is a routing and installation video [link here](#), that provides an overview of the hoses, fittings and other included components for this installation. This is for the GARMIN transducer only.

DELETIONS: VA-119

CHOICE #4- AIRWOLF REMOTE OIL FILTER RELOCATION KIT- If you want to move your oil filter to a much easier to access location for oil changes, you can order the AIRWOLF K007-F kit from either Airwolf or Aircraft Spruce. Make sure you get that configuration. Then, you can pair it with our relocation hoses in either standard or integral firesleeve and move your oil filter to the copilot side lower left firewall as shown in the images below.

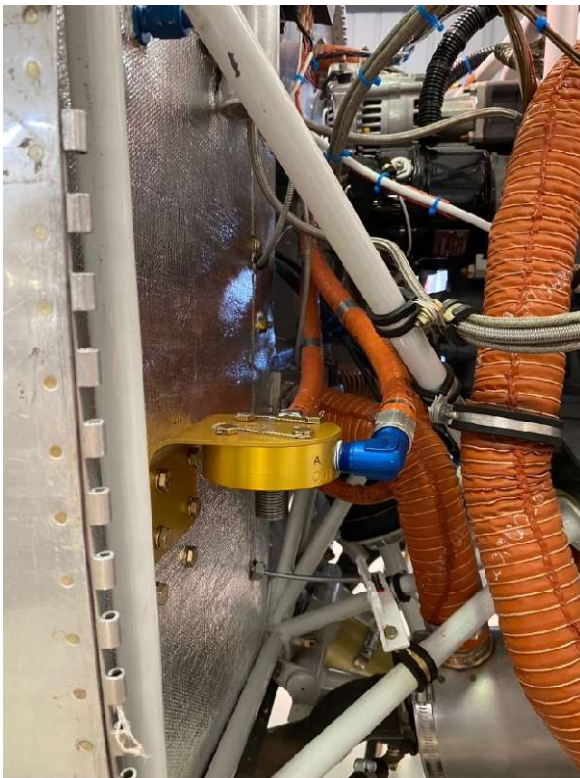

VERY IMPORTANT: Attach the hoses by hand **BEFORE** final mounting your Airwolf to the firewall. This will ensure the positioning of the filter is correct on the firewall with no stress on the hoses.



DELETIONS: NONE REQUIRED FOR AIRWOLF REMOTE FILTER INSTALLATION.

CHOICE #5 SDS/EFII INSTALLATION.

The EFII firewall forward installations for the RV10 has their own installation manual. The deletion list from Vans is as follows:

1. VA138, VA189, VA-102, VA-119, VA-135, VA-190

CHOICE #6 OIL DRAIN KIT – NO DELETIONS REQUIRED

The RV10 Oil Drain Kit provides you with conductive Teflon flex hoses and AN fittings to replace your standard IO540 drain lines with a high quality Teflon retrofit kit. (Example image shown below)



RV-10 Firewall Forward Rev 8 9-8-2023

Please feel free to reach out to us with any questions. We will continue to update this manual as we receive more pictures and add new items to the list.